

Technische fiche :

# **ES 420 DL**

---



Technical characteristics		Metrisch	
1.1	Manufacturer		Manitou
1.2	Model Name		ES 420 DL
1.3	Power source		Battery
1.4	Operator type		Pedestrian
1.5	Max. capacity	Q	2000 kg
1.51	Nominal capacity on wrapover forks	Q	1000 kg
1.52	Nominal capacity in double stacking 1 / 2	Q / Q	1000 kg + 1000 kg
1.6	Load centre of gravity	c	600 mm
1.8	Distance from Load backrest to center of rear axle	x	937 mm
1.9	Wheelbase	y	1644 mm
Weight			
2.1	Service weight		1020 kg
2.2	Weight on front axle (laden) / rear axle (laden)		1460 kg / 1560 kg
2.3	Weight on front axle (Unladen) / rear axle (Unladen)		730 kg / 290 kg
Wheels			
3.1	Tyres type		Polyurethane
3.5.2	Number of drive wheels / Size of drive wheels		1x230x75
3.3	Number of load wheels / Size of load wheels		4 / 82x68
3.4	Number of stabilizer wheels / Size of the stabilizer wheels		2 / 120x50
3.5	Number of front wheels / rear wheels		3 / 4
3.6	Front wheel gauge	b10	435 mm
3.7	Rear wheel gauge	b11	380 mm
Dimensions			
4.9	Height tiller min. / max.	h14 / h14	866 mm / 1320 mm
4.15	Fork height in low position	h13	85 mm
4.19	Overall length	l1	2060 mm
4.20	Length to face of forks	l2	870 mm
4.21	Overall width	b1	688 mm
4.22	Forks section / width / length	s / e / l	160 mm / 180 mm / 1190 mm
4.24	Fork carriage width	b3	650 mm
4.31	Ground clearance below mast	m1	25 mm
4.32	Ground clearance at centre of wheelbase	m2	30 mm
4.35	Turning radius	Wa	1870 mm
Performances			
5.1	Travel speed (laden / unladen)		5.50 km/h / 6 km/h
5.2	Lifting speed (laden / unladen)		0.11 m/s / 0.18 m/s
5.3	Lowering speed (laden / unladen)		0.20 m/s / 0.24 m/s
5.10	Service brake		Electro magnetic
Engine			
6.1	Drive motor rating S2 60 min		1.70 kW
6.2	Lift motor rating at S3 15%		2 kW
6.3	Battery according to DIN 43531/35/36 A, B, C		No
6.4	Battery / Batteries capacity		24 V / 270 Ah
6.5	Battery weight (+/- 5%)		245 kg
Miscellaneous			
8.1	Type of drive control		AC
8.4	Sound level at the driver's ear according to DIN 12 053		65 dB

## ES 420 DL - Tekening met afmetingen

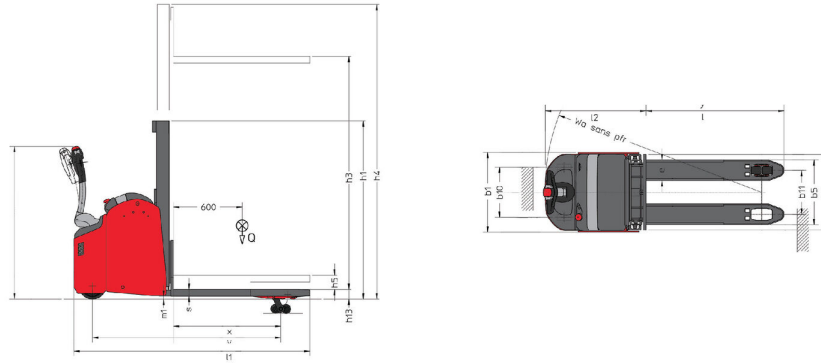

## Kenmerken van de masten en restcapaciteiten

Central Cylinder Duplex		CCD 17	CCD 21
h3 - Mast lifting height *	mm	1725	2125
h1 - Mast height lowered	mm	1365	1560
h4 - Mast height extended	mm	2185	2580
Residual capacity without attachment (Industrial load chart)	kg	1000	1000
h5 - Initial lift	mm	125	125

Central Cylinder Simplex		CCS 17
h3 - Mast lifting height *	mm	1725
h2 - Mast free lift *	mm	1725
h1 - Mast height lowered	mm	2180
h4 - Mast height extended	mm	2180
Residual capacity without attachment (Industrial load chart)	kg	1000
h5 - Initial lift	mm	125

Free Lift Triplex		FLT 21
h3 - Mast lifting height *	mm	2110
h1 - Mast height lowered	mm	1110
h4 - Mast height extended	mm	2485
Residual capacity without attachment (Industrial load chart)	kg	1000
h5 - Initial lift	mm	125

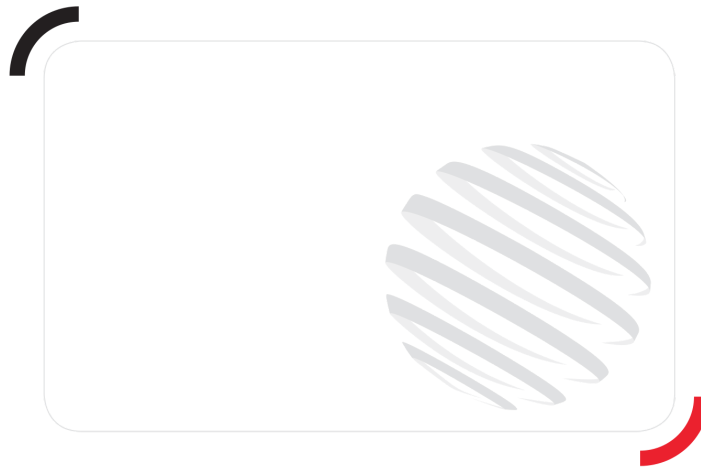

# **MANITOU** **HANDLING YOUR WORLD**

Siège Social

430 rue de l'Aubinière - 44150 Ancenis Cedex - France

Tel: +33(0)2 40 09 10 11 - Fax: +33 (0)2 40 09 10 97

[www.manitou.com](http://www.manitou.com)



Deze publicatie geeft een beschrijving van de versies en configuratiemogelijkheden van de Manitou-producten, waarvan de uitrusting kan verschillen. De afgebeelde uitrustingen in deze brochure kunnen standaard, optioneel of niet leverbaar zijn, afhankelijk van de versies. Manitou behoudt zich het recht voor om op te allen tijde en zonder voorafgaande kennisgeving de vermelde specificaties te wijzigen. De weergegeven specificaties zijn niet bindend voor de fabrikant. Voor meer bijzonderheden kunt u uw Manitou dealer raadplegen. Dit document is niet contractueel. De presentatie van de producten is niet contractueel. Specificatielijst is niet uitputtend. De logo's, evenals de visuele identiteit van de onderneming zijn eigendom van Manitou en mogen niet zonder toestemming worden gebruikt. Alle rechten voorbehouden. De foto's en schema's in deze brochure zijn bedoeld als informatie en zijn indicatief.

MANITOU BF NV - Naamloze vennootschap met raad van bestuur - Kapitaal: 39 668 399 euro - 857 802 508 RCS Nantes